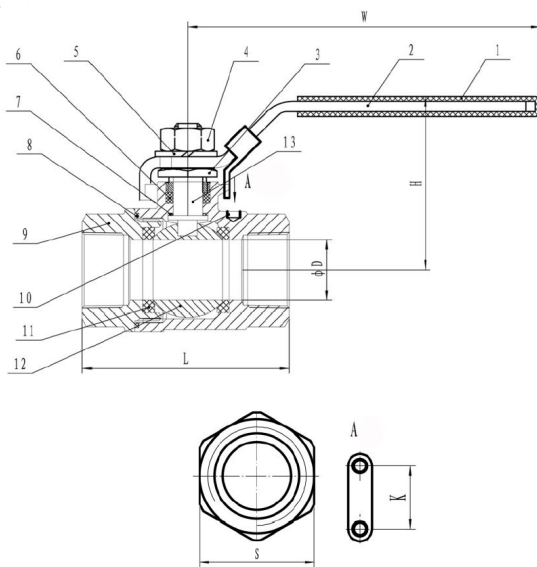
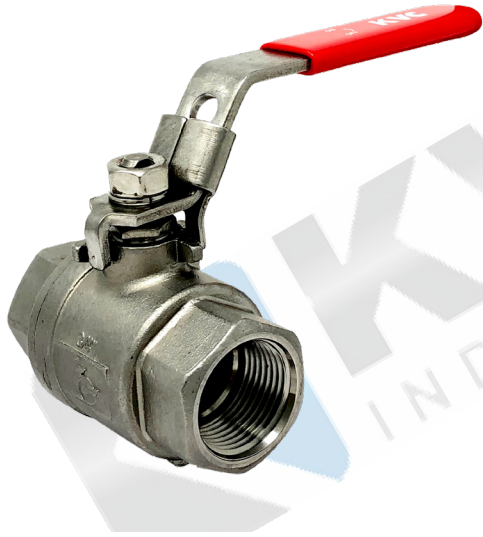

FIG. S-201T:

1000 WOG 2-PIECE STAINLESS STEEL BALL VALVE FULL PORT THREADED ENDS W/LOCKING LEVER HANDLE

Features:

- Two-piece design for fast, economical in-line maintenance
- Basic design complied with ANSI B16.34
- NPT threaded ends complied with ANSI B 1.20.1., BS21, DIN 259/2999
- Tested according to API 598.
- Locking Lever handle
- Floating ball
- Investment casting



Materials:

No.	Part Name	Specification
1	Handle Cover	Plastic
2	Handle	304SS
3	Gland Nut	316SS
4	Stem Nut	304SS
5	Spring Washer	304SS
6	Stem Packing	PTFE
7	Thrust Washer	PTFE
8	Joint Gasket	PTFE
9	Cap	316SS
10	Body	316SS
11	Seat	PTFE
12	Ball	316SS
13	Stem	316SS

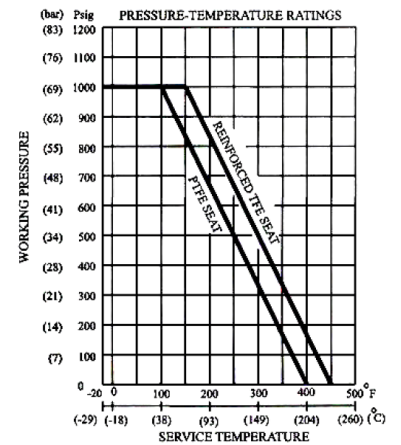

Dimension:

Size		D		L		H		W		S		K	
in	mm	in	mm	in	mm	in	mm	in	mm	in	mm	in	mm
1/4	8	0.36	9.2	2.13	54.30	1.88	48	4.01	102	1.00	25.00	1.12	28.50
3/8	10	0.36	9.2	2.13	54.30	1.88	48	4.01	102	1.00	25.00	1.12	28.50
1/2	15	0.50	12.7	2.40	61.00	2.04	52	4.65	118	1.18	30.00	1.12	28.50
3/4	20	0.75	20	2.75	70.00	2.40	61	4.65	118	1.42	36.00	1.37	34.80
1	25	1.00	25	3.22	82.00	2.55	65	5.82	148	1.75	44.60	1.37	34.80
1 1/4	32	1.25	32	3.60	91.50	3.11	79	5.82	148	2.12	54.00	1.50	38.10
1 1/2	40	1.49	38	4.44	113.00	3.26	83	6.38	162	2.40	61.00	1.50	38.10
2	50	2.00	50	4.88	124.00	3.81	97	6.38	162	2.75	70.00	1.50	38.10
2 1/2	65	2.51	64	6.50	165.10	5.07	129	9.61	244	3.30	84.00	2.18	55.50
3	80	2.99	76	7.44	189.00	5.43	138	9.60	244	3.89	99.00	2.18	55.50
4	100	3.70	94	9.44	240.00	6.88	175	12.48	317	5.11	130.00	2.48	63.00